 中国驰名商标 国家高新技术企业



C-Lin

欣灵电气股份有限公司
XINLING ELECTRICAL CO., LTD.

地址：浙江乐清经济开发区纬十九路328号/浦南五路55号
热线：0577-62735555 传真：0577-62722963
Http://www.c-lin.cn Email: xl@xinling.com
技术服务热线：400 1663 188



中国驰名商标 国家高新技术企业

C-Lin 欣灵

使用说明书
Products Instructions

XLGL 系列-隔离开关
(125A-3150A)

非常感谢您使用欣灵牌隔离开关,使用前请
阅读使用说明书!

28A003E0

使用环境 Service environment

- ▶ XLGL 负荷-隔离开关在下列条件下能可靠工作;
XLGL load-isolation switch can operate under the following conditions;
- ▶ 海拔高度不超过2000米;
Altitude not more than 2000m;
- ▶ 环境温度不高于40℃, 不低于-5℃;
The range of ambient temperature is from 5℃ to 40℃;
- ▶ 相对湿度不大于95%;
Relative humidity not more than 95%;
- ▶ 无爆炸危险介质环境;
The environment without any explosive medium;
- ▶ 无雨雪侵袭环境;
The environment without any rain or snow attacking.

注: 若预期使用于周围空气温度高于+40℃或低于-5℃~-45℃的条件下, 用户应向制造厂说明。
Note: If the product is expected to be used in the environment where temperature is over +40℃ or below -5℃ ~ -45℃, users shall tell it to the manufacturer.

用途 Application

交流50赫兹, 额定电压至660V, 直流额定电压至440V, 额定电流至1600A。用于不频繁接通与分断电路。
AC 50Hz, rated voltage 660V, DC rated voltage 440V, rated current 1600A. It is used for making and breaking circuit infrequently.



表 (Table)

一常开一常闭 One NO and one NC	11	NO+NC
二常开二常闭 Two NO and Two NC	22	2NO+2NC

选型举例: 额定电流630A, 有中极性转换负荷一
离开关, 柜外操作HGLZ-630A/4J
Example for lectotype: Rated current 630A, include neutral pole
transferring load isolation switch, HGLZ-630A / 4J for operating
outside of cabinet

使用环境 Service environment

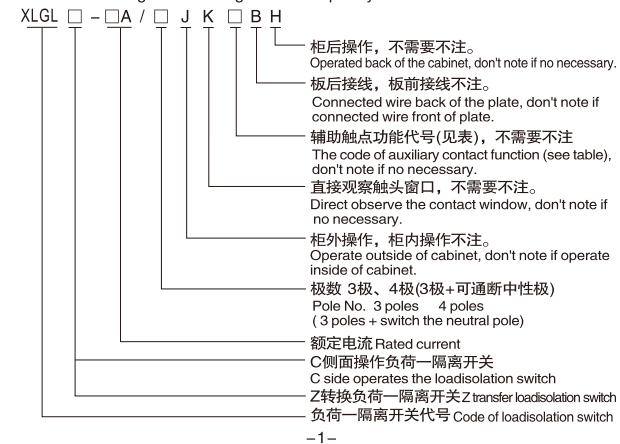
- ▶ XLGL负荷一隔离开关从125~3150A分18个规格是模块化设计基础型, 具有三极, 四极(三极+可通断中性极), 适用于电路和接通与分断或电气隔离, 1000A以上只做电气隔离。
- ▶ 正面设有标记窗口指示触头通断状态。
- ▶ 根据需要可提供后面观察窗口, 直接观察触头通断状态, 窗口样式见RGL-125~1600A/H柜后操作负荷一隔离开关。
- ▶ XLGLoad isolation switch can be divided into 18 specs from 125A to 3150A, it is the basic type of module design, it has three poles and four poles (three poles + switch neutral pole), applied to make and break circuit or electric isolate, over 1000A is only for electric isolation.
- ▶ Symbol window on front face indicates the contact on-off state.

操作方式 Operation mode

- ▶ 直接操作: 手柄直接安装在开关中间。
Direct operation: The handle is installed in the middle of switch directly.
- ▶ 柜外操作: 手柄安装在配电柜柜门外。
Operate outside of cabinet: The handle is installed outside of distribution cabinet.
- ▶ 可配装两组辅助触点。
It can be assembled two groups auxiliary contacts.

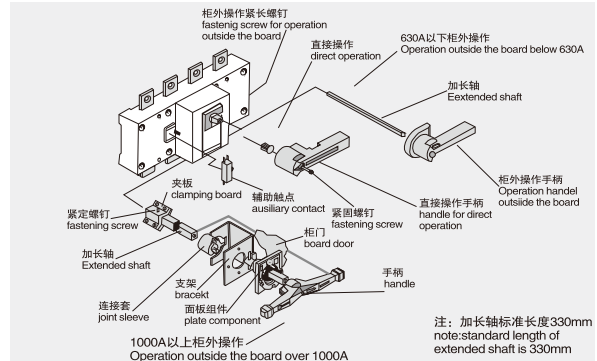

125~3150A 电器性能与机械性能
Electrical Properties and Mechanical Properties

约定发热电流 Ith (A) Conventional heating current	125	160	200	250	315	400	500	630	1000	1250	1600	2000	2500	3150
约定发热电压 Ui (V) Rated insulation voltage Ui (V)	750	750	750	750	1000	1000	1000	1000	1000	1000	1000	1000	1000	1000
介电强度 V Dielectric strength	5000	5000	5000	5000	8000	8000	8000	8000	10000	10000	10000	10000	10000	10000
额定冲击耐受电压 Uimp (KV)(安 安类别V) Rated impact withstand voltage Uimp (KV) (Installation sort IV)	8	8	8	8	12	12	12	12	12	12	12	12	12	12
额定工作电流 Ie(A) Rated working current Ie(A)														
380V AC21	125	160	200	250	315	400	500	630	1000	1250	1600	2000	2500	3150
AC22	125	160	200	250	315	400	500	630	1000	1250	1600	2000	2500	2500
AC23	125	160	200	250	315	340	425	500	800	1000	1250	1250	1250	1250
660V AC21	125	160	160	200	315	400	400	500	1000	1000	1600	2000	2500	3150
AC22	125	160	160	160	315	315	315	315	800	800	800	2000	2000	2000
AC23	80	80	100	125	125	125	125	125	400	400	500	1000	1000	1000
220V AC21	125	160	200	250	315	400	500	630	1000	1250	1600	2000	2500	3150
AC22	125	160	200	250	315	400	400	500	1000	1250	1250	2000	2000	2000
AC23	125	125	160	200	315	400	400	500	1000	1250	1250	1250	1250	1250
440V AC21	100	125	160	200	315	400	400	500	1000	1250	1250	2000	2500	3150
AC22	100	125	160	200	315	400	400	500	1000	1250	1250	1250	1250	1250
AC23	100	125	160	200	315	400	400	500	1000	1000	1000	1000	1000	1000
电动机功率 P(KW) Motor power P(KW)														
380V	63	80	100	132	160	220	280	315	560	560	560	710	710	710
660V	75	75	90	110	185	185	185	185	475	475	475	750	750	750
过载能力 Overload capacity														
额定短时耐受电流 Ikt(KA Rms) 0.1S/1.0S Rated short-time withstand current Ikt(KA Rms)0.1S/1.0S	20	20	30	30	45	45	50	50	90	90	90	90	90	90
10	10	12	12	20	20	25	25	50	50	50	50	50	50	50
接通分断能力 Making and breaking capacity														
额定接通能力 Icn(A Rms)AC23 380V AC23 380V Rated making capacity Icn(A Rms) AC23 380V	1250	1250	2000	2000	3150	4000	4000	4000	10000	10000	10000	10000	10000	10000
额定分断能力 Icm(A Rms)AC23 380V AC23 380V Rated breaking capacity Icm (A Rms)AC23 380V	1000	1000	1600	1600	2500	3200	3200	3200	8000	8000	8000	8000	8000	8000
额定短路接通能力 Icm(KA峰值) Rated short-circuit making capacity Icm (KA peak value)	12	12	17	17	30	30	40	40	70	70	70	70	70	70
机械寿命(循环操作次数) Mechanical life (rotation operation time)	10000	10000	10000	10000	5500	5500	5500	5500	4000	4000	3000	2500	2500	2500
电气寿命(循环操作次数) Electrical life (rotation operation time)														
额定电压 Ue=660V 额定电流 Ie Rated voltage Ue=660V Rated current Ie	1500	1500	1500	1500	750	750	750	750	600	600	450	400	400	350
COS φ=0.95 AC21	1000	1000	1000	1000	500	500	500	500	400	400	300	200	200	200
COS φ=0.85 AC22	500	500	500	500	250	250	250	250	200	200	150	100	100	100
COS φ=0.35 AC23														
操作力距(Nm) Operation moment (Nm)	6.5	6.5	10	10	14.5	14.5	14.5	14.5	27	27	27	60	60	60
重量(Kg) Weight (Kg)														
3极 3 poles	1	1	2	2	3.5	3.5	4	4	10.5	10.5	16	31	31	42
4极 4 poles	1.5	1.5	2.5	2.5	4	4	4.5	4.5	13	13	20	40	40	49

外形与安装尺寸 External Dimension and Installation Dimension

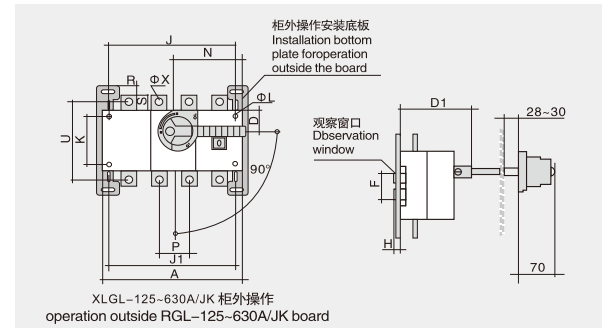
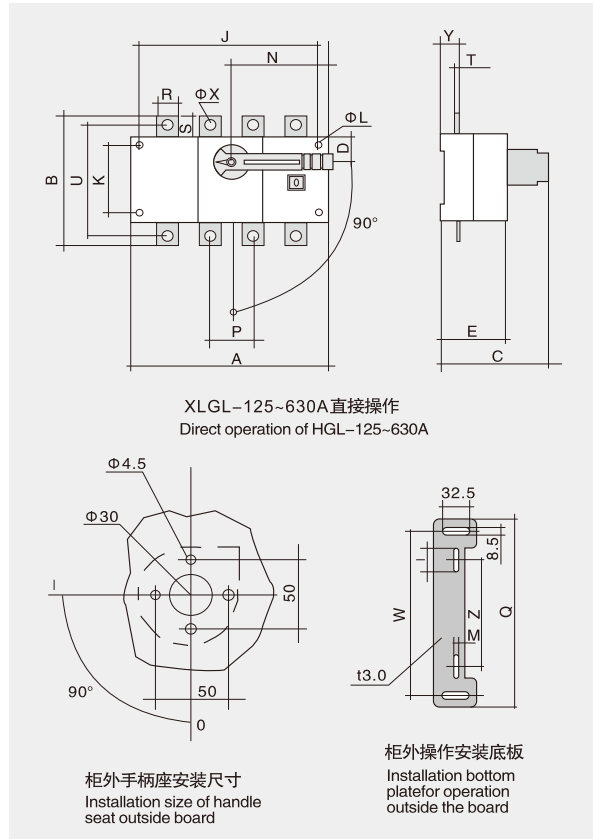

规格 Specification	底板尺寸 Dimension of Bottom Board					规格 Specification	底板尺寸 Dimension of Bottom Board				
XLGL-125~630A	I	M	Z	W	Q	XLGL-125~630A	I	M	Z	W	Q
125A	55	5.5	85	190	218	315A	60	6.5	130	240	270
160A	55	5.5	85	190	218	400A	60	6.5	130	240	270
200A	55	5.5	85	190	218	500A	60	6.5	130	240	270
250A	55	5.5	85	190	218	630A	60	6.5	130	240	270

规格 Specification	外型尺寸与安装尺寸 External Dimension and Installation Dimension																			
	A	B	C	D	D1	E	ϕL	J	J1	K	N	P	R	S	T	U	ϕX	Y	F	H
XLGL-125-630A	140	135	125	27	92	73	5.5	120	120	65	85	36	20	25	3.5	115	9	25	59	10
125A/3	140	135	125	27	92	73	5.5	150	150	65	85	36	20	25	3.5	115	9	25	59	10
125A/4	170	135	125	27	92	73	5.5	120	120	65	85	36	20	25	3.5	115	9	25	59	10
160A/3	140	135	125	27	92	73	5.5	150	150	65	85	36	20	25	3.5	115	9	25	59	10
160A/4	170	135	125	27	92	73	5.5	150	150	65	85	36	20	25	3.5	115	9	25	59	10
200A/3	180	170	138	35	98	86	5.5	160	160	90	115	50	25	30	3.5	140	11	25	76	15
200A/4	230	170	138	35	98	86	5.5	210	210	90	115	50	25	30	3.5	140	11	25	76	15
250A/3	180	170	138	35	98	86	5.5	160	160	90	115	50	25	30	3.5	140	11	25	76	15
250A/4	230	170	138	35	98	86	5.5	210	210	90	115	50	25	30	3.5	140	11	25	76	15
315A/3	230	240	165	50	135	110	7	210	210	140	145	65	32	40	5	206	11	37	94	20
315A/4	295	240	165	50	135	110	7	275	275	140	145	65	32	40	5	206	11	37	94	20
400A/3	230	240	165	50	135	110	7	210	210	140	145	65	32	40	5	206	11	37	94	20
400A/4	295	240	165	50	135	110	7	275	275	140	145	65	32	40	5	206	11	37	94	20
500A/3	230	260	165	50	135	110	7	210	210	140	145	65	40	50	6	220	13	37	94	20
500A/4	295	260	165	50	135	110	7	275	275	140	145	65	40	50	6	220	13	37	94	20
630A/3	230	260	165	50	135	110	7	210	210	140	145	65	40	50	6	220	13	37	94	20
630A/4	295	260	165	50	135	110	7	275	275	140	145	65	40	50	6	220	13	37	94	20

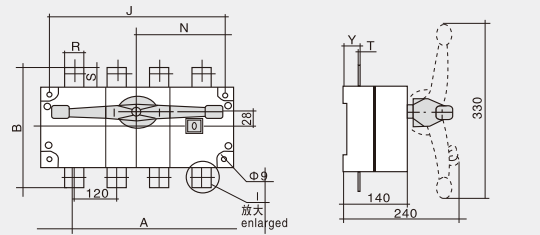

XLGL-1000~1600A直接操作
Direct operation of HGL-1000~1600A

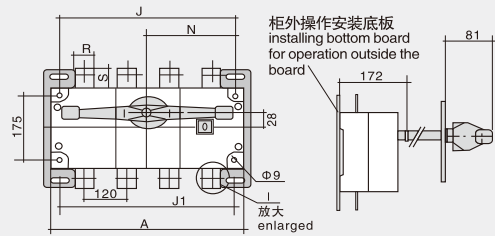

XLGL-1000~1600A/J柜外操作
operation outside XLGL-1000~1600A/J board

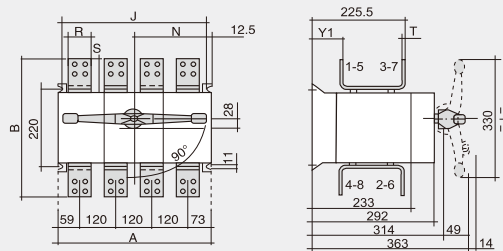

XLGL-2000~2500A正面直接操作
Direct operation on front face XLGL-2000~2500A

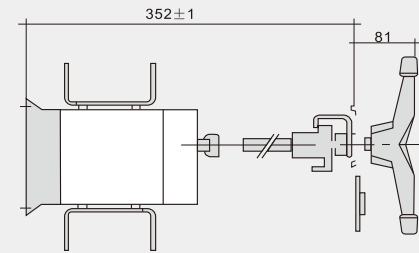

XLGL-2000~2500A正面柜外操作
operation outside HGL-2000~2500A

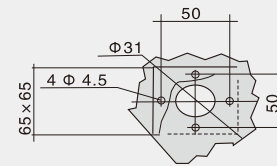

柜外手柄座安装尺寸
Installation size of handle
seat outside board

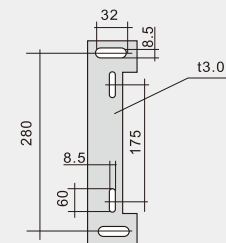

柜外操作安装底板
Installation bottom board for
operation outside the board

接线端子 Connecting terminal

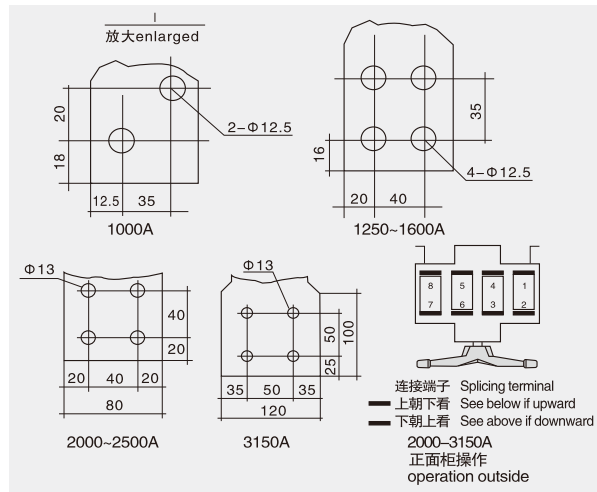

外形与安装尺寸 External Dimension and Installation Dimension

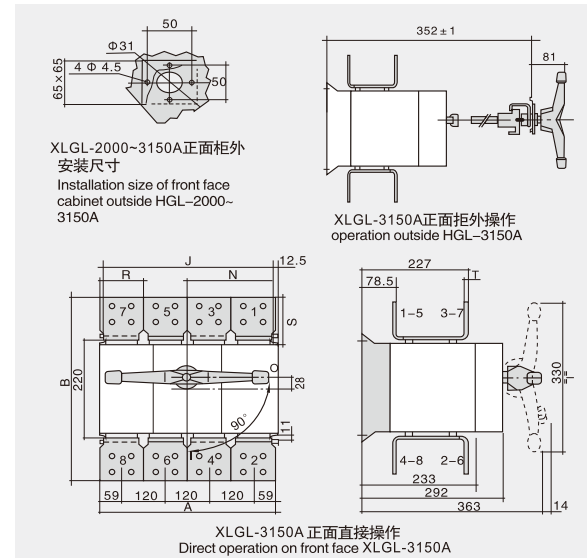
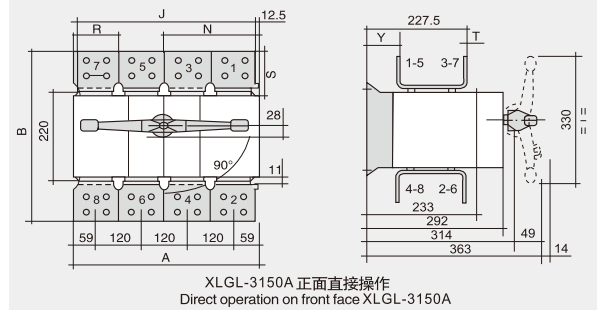

规格 Specification	外形尺寸与安装尺寸 External Dimension and Installation Dimension								
	A	B	J	J1	N	R	S	T	Y
XLGL-100~1600A									
1000A/3	378	312	355	355	174	60	56	8	48
1000A/4	492	312	473	373	234	60	56	8	48
1250A/3	378	338	355	355	174	80	69	8	48
1250A/4	492	338	473	473	234	80	69	8	48
1600A/3	378	338	355	355	174	80	69	10	49
1600A/4	492	338	473	473	234	80	69	10	49
2000A/3	378	455	355	355	173.5	80	127.5	10	78.5
2000A/4	492	455	473	473	233.5	80	127.5	10	78.5
2500A/3	378	455	355	355	173.5	80	127.5	10	78.5
2500A/4	492	455	473	473	233.5	80	127.5	10	78.5
3150A/3	378	505	355	355	173.5	120	152.5	12	78.5
3150A/4	492	505	473	473	233.5	120	152.5	12	78.5

安装示意说明 Installation instructions

1. XLGL-630A 及以下柜内操作开关的说明书

如图1所示：将开关垂直固定安装在开关柜内安装板上，并使开关处于断开“0”位置；将涨块插入开关方轴的孔内，把手柄套在开关方轴上，并使用手柄处于水平位置；然后用自攻螺钉从手柄孔中拧入涨块内。

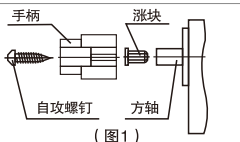

(图1)

2. XLGL-1000A 及以上柜内操作开关的安装说明：

如图2所示：将开关垂直固定安装在开关柜内安装板上，并使开关处于断开“0”位置；把手柄套在开关方轴上，并使手柄处于水平位置；然后将平头螺钉将手柄固定在开关方轴上并拧紧。

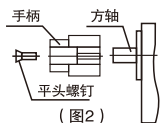

(图2)

3. XLGL-630A 及以下柜外操作开关的安装说明

(1)如图3所示，将开关垂直固定安装在开关柜安装板上，并使用天并处于断开“0”位置，再测出天关方轴顶端到柜门内侧表面距离L。

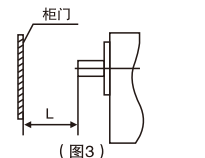

(图3)

(2)如图4所示：在加长轴插销端测量出(L+66)mm的长度后，将长出多余的部分锯断。

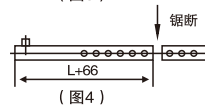

(图4)

(3)如图5所示：若不需要柜门联锁（即开关闭合时，柜门打不开；柜门打开时，开关无法闭合），则用老虎钳将加长轴插销端的黑色圆柱销拔出即可；若需要柜门联锁，则不用拔出。然后将加长轴插入开关方轴的孔内并插到底，再拧紧开关方轴中的紧固螺钉。

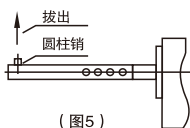

(图5)

(4)如图6所示，用手锤从柜外轻击柜门与加长轴顶端的接触外以确定孔中心，并在钻孔中心处从柜门内侧往外钻孔Φ6再扩孔Φ30。

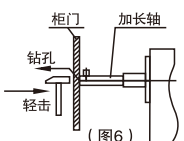

(图6)

(5)如图7所示：将圆盘端盖凸出的中心部份卡在柜门Φ30的孔中，并以端盖的4小孔定位，在柜门的左右水平方向与上下垂直方向上钻孔4-Φ4.5，然后用手锤将端盖凸出的中心部分敲掉。

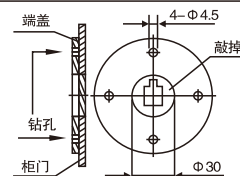

(图7)

(6)如图所示：用随机附件的2个月攻螺钉螺钉与平垫将圆盘端盖（装柜门内侧）与手柄（装柜门外侧）固定在柜门的开孔处，安装时手柄应处于水平位置，并指标“0”位。

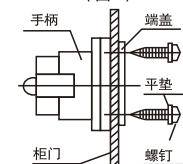

(图8)

4. XLGL-1000A 有以上柜外操作开关的安装说明

(1)如图9所示：将开关垂直固定安装在开关柜内安装板上，并使开关处于断开“0”位置；再测出开关方轴顶端到柜门内侧表面距离L。

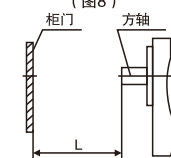

(图9)

(2)如图10所示：将定位轴螺纹端拧入加长轴螺孔中并拧紧到位，在加长轴上连同定位轴测量出(L)的长度后，将长多余的部分锯断。

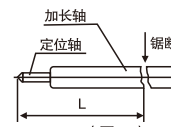

(图10)

(3)如图11所示：用定位夹板及附件螺栓将加长轴与开头方轴连接并拧紧定位钉；通过调整定位轴使用其端与柜门接触，并用手锤从柜外轻击该处以确定钻孔中心；然后拆除定位轴，并在钻孔中心处从柜门内侧往外钻孔Φ6再扩孔Φ30。

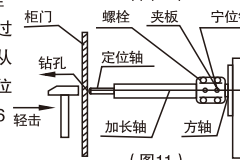

(图11)

(4)如图12所示：用附件中较短的一平头螺钉将连接（铝）套固定在加长轴上，并使凸筋力平指向左边（即开关“0”位）；将面板组件穿入装在柜门Φ30的孔中，并使面板中指示件的指示方向与连接套中凸筋的方向一致；然后关上柜门，并以面板中左、右、上3注孔定位钻孔3-Φ5。

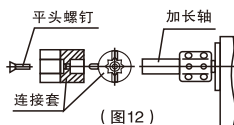

(图12)

(5)如图13所示：用附件中较长的3个平头螺钉将面板组件（装柜门外侧）与U型支架（装柜门内侧）装在柜门的开孔处，并使U型支架的U型口在右手门时朝向左边、在左手门时朝向右边。

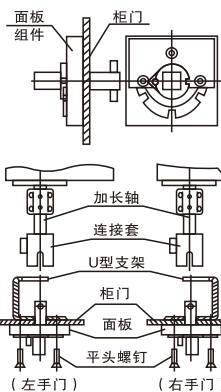

(图13)

(6)如图14所示：将标识牌粘贴在面板上，并粘贴端正牢靠；然后将手柄套在面板方轴上，并使手柄指向标识“0”位；然后用平头螺钉将手柄固定在面板方轴并拧紧螺钉。



(图14)

5.XLGLC、XLGLCK、XLGLZ、XLGLB 柜内安装式同XLGL-1000A及以上柜内操作；XLGL柜外操作，XLGLH柜后操作安装方式：

(1)630A及以下同XLGL-630及以下柜外操作

(2)1000A及以上同XLGL-1000A及以上柜外操作；XLGLC、HGLCK、HGLZ 柜外操作安装方式同XLGL-1000A及以上柜外操作。